

# MONOGRAM

TAILOR-MADE WINDOW DRESSINGS

## MONOGRAM CASSETTE ROMAN BLIND FITTING INSTRUCTIONS

### PREPARATION

- 1 The screws we've provided are for wood use only. If you are fitting into a wall or lintel, you will require different screws and rawl plugs.
- 2 Decide how the brackets will be fitted. Options are: Top fix or face fix as shown in Fig. 1 (Top fix is typically used for ceiling and lintel recess fitting. Face fix is commonly used for wall or window frame fitting).
- 3 Using a pencil mark where the brackets are to be fixed. We recommend approximately 100mm in from each side. Avoid fitting them over the control chain. Larger blinds will need all the brackets supplied to be used evenly across the width of the headrail. Fig. 2.

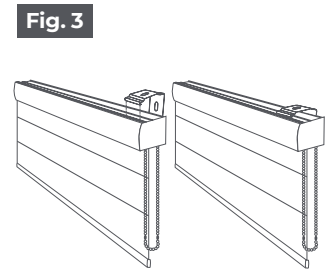
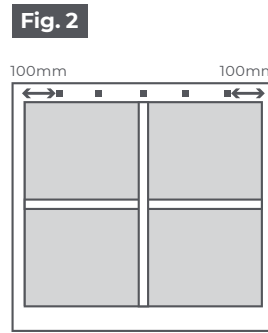
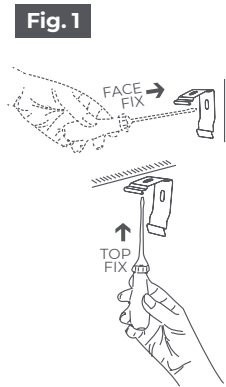

### FITTING THE BLIND

- 1 Fix the brackets into position with the correct fixing type.
- 2 Hook the front ridge of the cassette into the front of the top bracket. See Fig. 3.
- 3 Push the cassette up until the back ridge slides in and clips to the back of the top bracket.
- 4 The cassette should click into place. Repeat until all brackets have been secured onto the cassette.

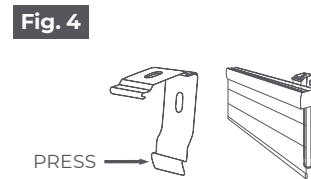

### OPERATING YOUR BLIND

To allow your blind to raise up and down, pull the chain and adjust the blind to desired level. Ensure you do not continue pulling the chain once the blind is fully retracted as this will damage the blind.

### HOW TO REMOVE THE BLIND FOR CLEANING

If you need to remove the blind from the brackets, press the release tab at the bottom of each bracket and tilt the headrail backwards. See Fig. 4.

### PARTS IDENTIFIED

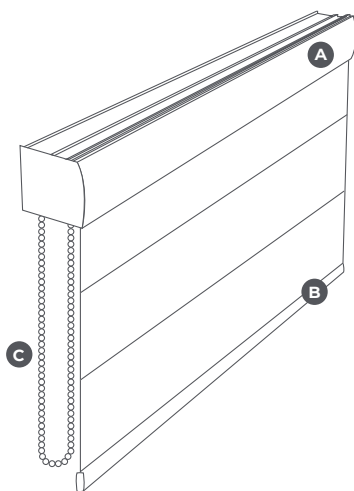

TOP / FACE FIX BRACKETS

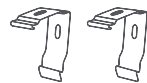

SCREWS



- A Cassette
- B Bottom Bar
- C Control Chain

### SAFETY DEVICE

To make the blind child safe, we've supplied a child safety device. Ensure this is added to the chain and securely fix to the wall at the maximum distance (making the chain fully taut).

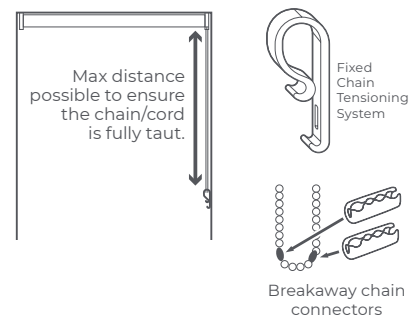

### TOOLS REQUIRED



### BLINDS CHILD SAFETY AWARENESS

Keep all cords and chains out of the reach of children. Loose cords or chains should never be tied together.