

PRESS BENCH ASSEMBLY INSTRUCTIONS

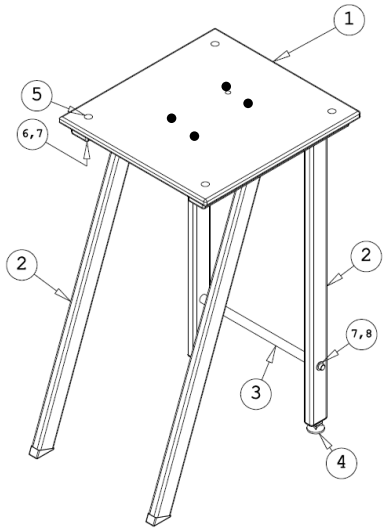

Parts list:

Item no.	Qty	Description
1	1	Bench top
2	2	Bench legs
3	1	Bracing bar
4	2	Adjustable feet
5	4	M8 x 60mm coach bolts
6	4	M8 nuts
7	6	M8 washers
8	2	M8 x 40 bolts

Tools required but not supplied:

Adjustable spanner

Step 1

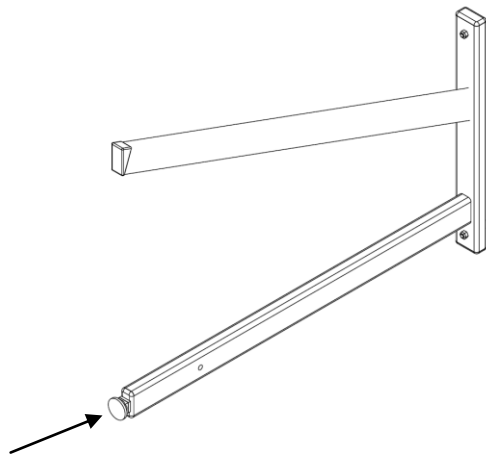

Screw the adjustable feet (item no. 4) into the threaded hole on the bottom of each of the rear legs

Step 2

Use 2 domed coach bolts, washers & nuts to fix the bench top to the first leg (screw in tight so the square underside of the coach bolt bites in to the MDF top).

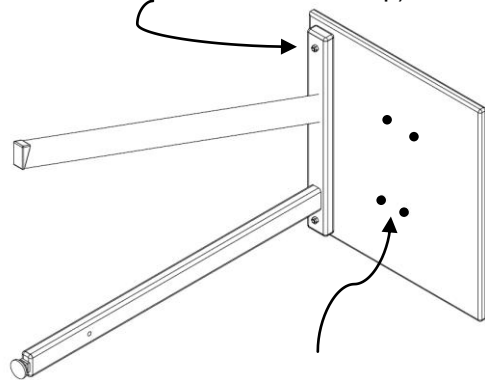

(Note the position of these holes).

Step's 3 & 4

Now fix the second leg in the same way.

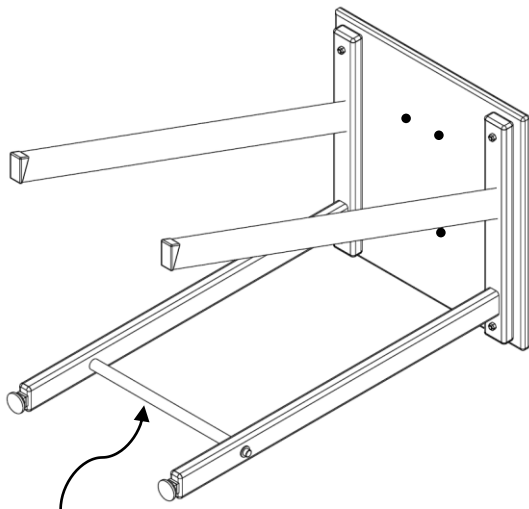

Now fit the rear brace bars between the legs using the M8 x 40mm bolts and washers.

Step 5

Stand the bench upright and ensure all fixings are tight.

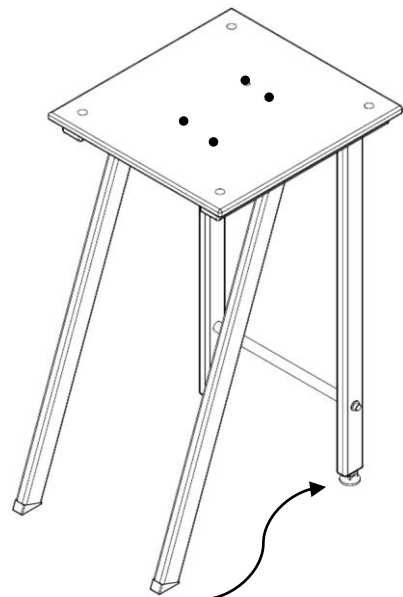

Use the 2 rear adjustable feet to level the bench.