

 Hallis

Curtain Eyelet Press

(Suitable for Eyelets up to 66mm Diameter)

User Manual

Combination Dies

Up to 40mm Curtain Eyelets

Separate V-Cutter & Setting Dies

Up to 66mm Curtain Eyelets

(Dies sold separately)

WARNING!

Health and Safety information
contained within.

Incorrect set-up can damage
this equipment.

**PLEASE READ
THIS MANUAL
BEFORE USE!**

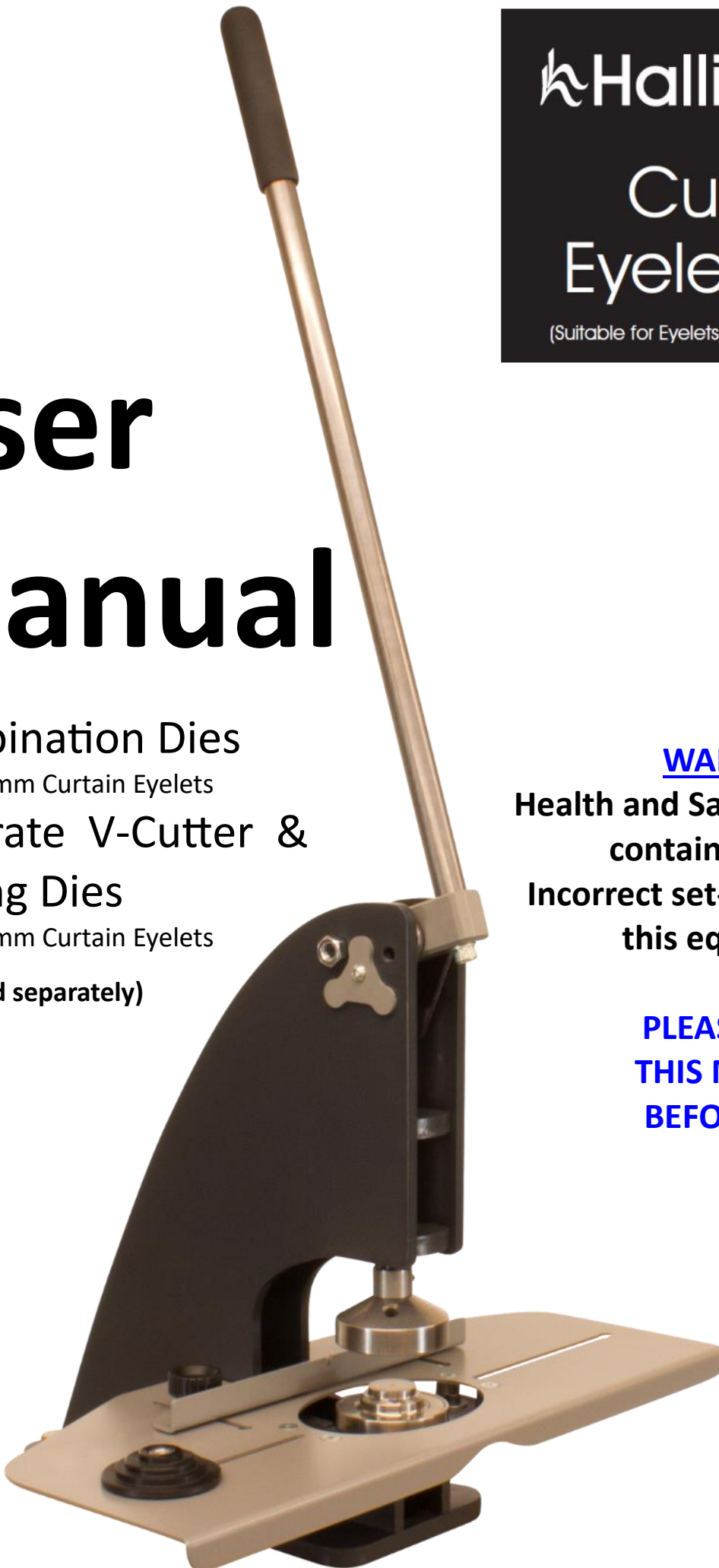

CONTENTS

Important safety information	2
About the machine	3
Front and rear operation options	4
Basic setup for first use	5
Machine use	6
Basic operation of the press	7
Combination Dies—Installation and setup	9
Combination Dies— Operation	10
Maintenance	11
Appendix A Inserting eyelets with the Separate V-Cutter & Setting Dies	12
Appendix B Change From Front to Rear Operation	14

IMPORTANT SAFETY INFORMATION

- The press is heavy (23kg) take care when moving.
- Be aware that there are sharp cutting edges on the dies.
- Keep hands away from dies when applying pressure.
- Keep hands away from the internal mechanism of the press.
- Always ensure the handle is in its resting position when changing dies or making adjustments.
- Be aware of the lever handle movement to avoid being stuck by it during operation.
- Follow the setup routines explained in this manual before first use.
- Always follow maintenance routines explained in the maintenance section.
- Please contact Hallis Hudson Sales Team if there is anything you don't understand.

ABOUT THE MACHINE.

Fig 1

Remove the machine and other parts from the packaging. In addition to this booklet and the setting dies you have ordered the following should also be included:

1. 1 x Curtain eyelet press body
2. 1 x Operating handle
3. 1 x Base plate with back stop and eyelet distance regulator
4. 3 x Hexagon keys (3mm, 5mm and 6mm)
5. 1 x 19mm x 24mm Spanner
6. 1 x M8 cap screw & washer
7. 2 x M6 cap screws & washers

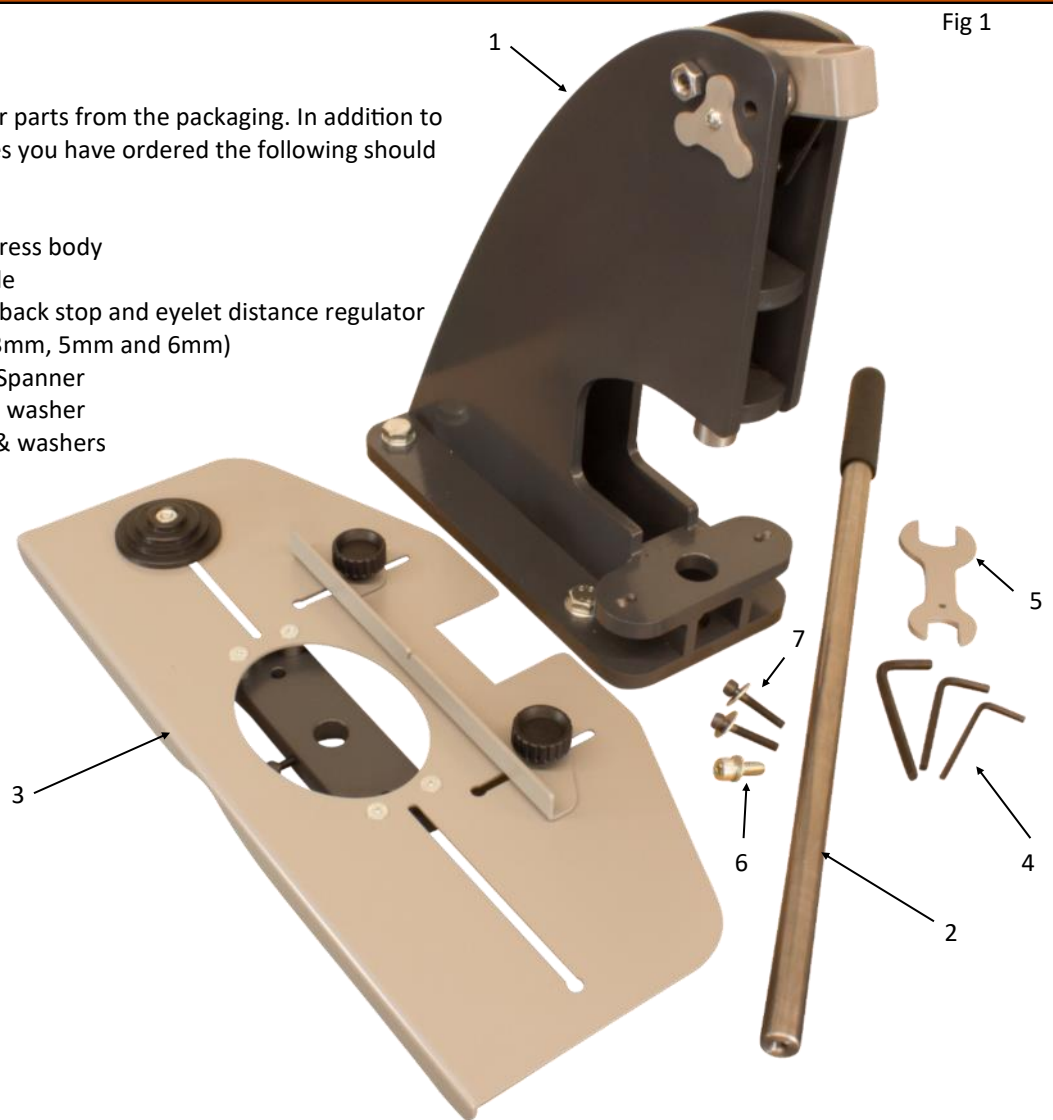

The curtain eyelet press machine cannot be operated without being first being bolted down to a suitable work bench. If you have purchased our self-assembly bench with this machine then please assemble this first and bolt the press to it using the nuts and bolts that are supplied with the bench.

Alternatively, fasten the machine to a suitably solid bench by drilling through the top surface and bolting the press to it securely using good quality fixings. The holes in the base will take 4 x M12 size bolts.

If you do not fasten the machine down in one of the above methods, then it will not cut material or set the eyelets. It will also want to tip forward potentially injuring the operator!

Fig 2

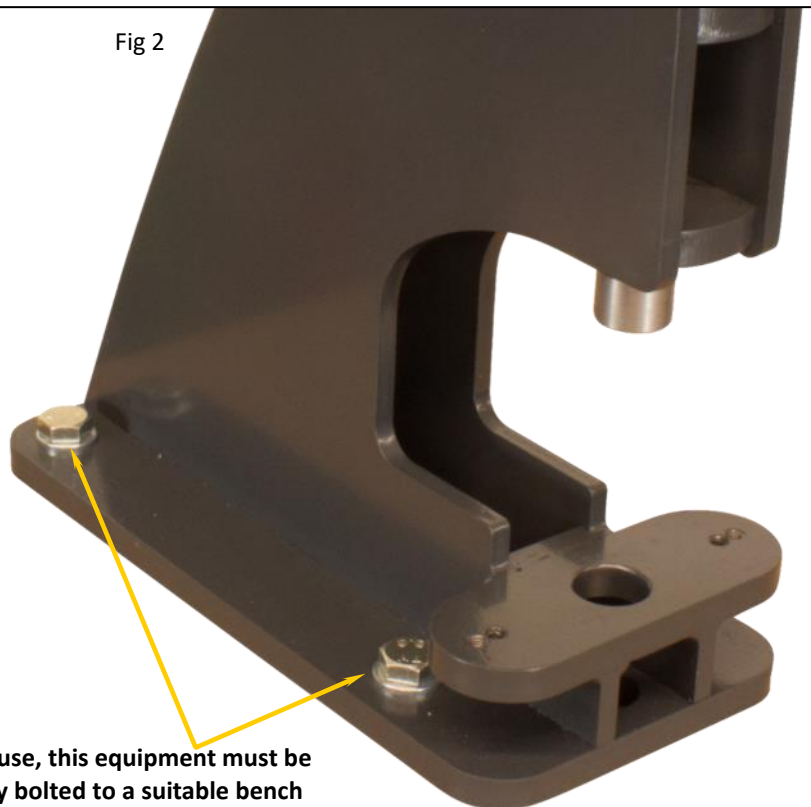

Before use, this equipment must be securely bolted to a suitable bench using the fixing holes at it's base.

FRONT AND REAR OPERATION OPTIONS

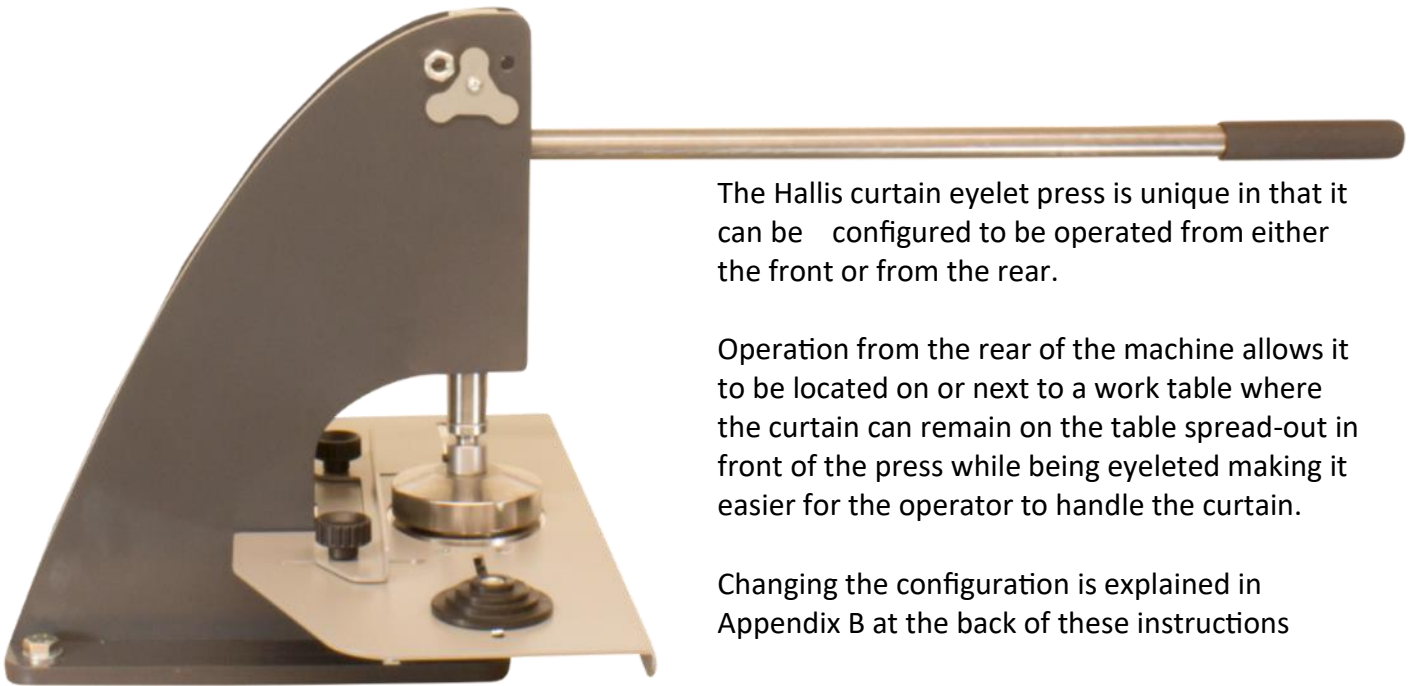

Fig 3 Above shows the curtain eyelet press setup to be operated from the front.

The Hallis curtain eyelet press is unique in that it can be configured to be operated from either the front or from the rear.

Operation from the rear of the machine allows it to be located on or next to a work table where the curtain can remain on the table spread-out in front of the press while being eyeleted making it easier for the operator to handle the curtain.

Changing the configuration is explained in Appendix B at the back of these instructions

For the purposes of these instructions all operations detailed are shown on a machine configured to operate from the front however operation from the rear is identical.

Fig 4 Below shows the Curtain eyelet press setup to be operated from the rear.



BASIC MACHINE SETUP FOR FIRST USE.

Place the **base plate** on to the **press body** as shown below.

Fix in position using the 2 x **M6 cap screws** and **washers**, at this point it is not necessary to tighten these fully as this is done when setting the dies.



Insert the **operating handle** in to the hole in the drive unit at the top of the machine.



Screw the **M8 cap screw & washer** into the underside of the drive unit.

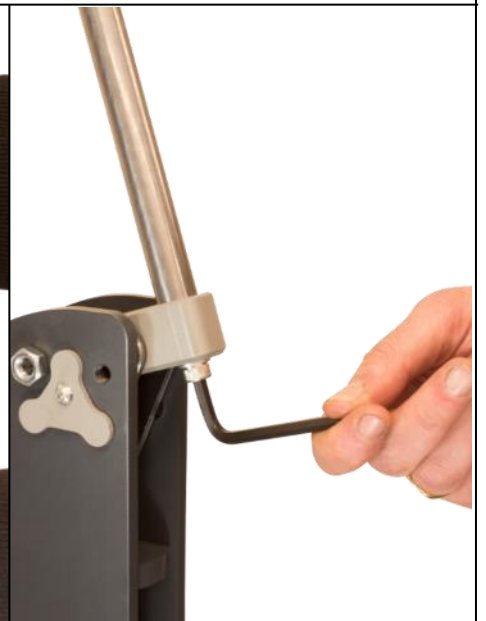

Tighten the **M8 cap screw** with the **6mm hex key**. The machine is now ready to fit the dies.

MACHINE USE

This machine allows the user to insert eyelets in fabric. By changing the dies (see fig 10) different size eyelets can be fitted.

Depending on your order requirements this machine will have been supplied with either combination type dies that both cut the material and fit the eyelet in one sequence with out the need to change the dies (see Fig 9) or separate V-cutter and setting dies (see Figure 10).

This manual describes and illustrates the setup and operation procedure to insert 40mm curtain eyelets using a Hallis Eyelet Press using the combination dies; the process is the same for all sizes of eyelet when using combination dies.

Alternate instructions are available if you are using separate V-cutter & Setting dies in Appendix A at the back of this manual.

Fig 9

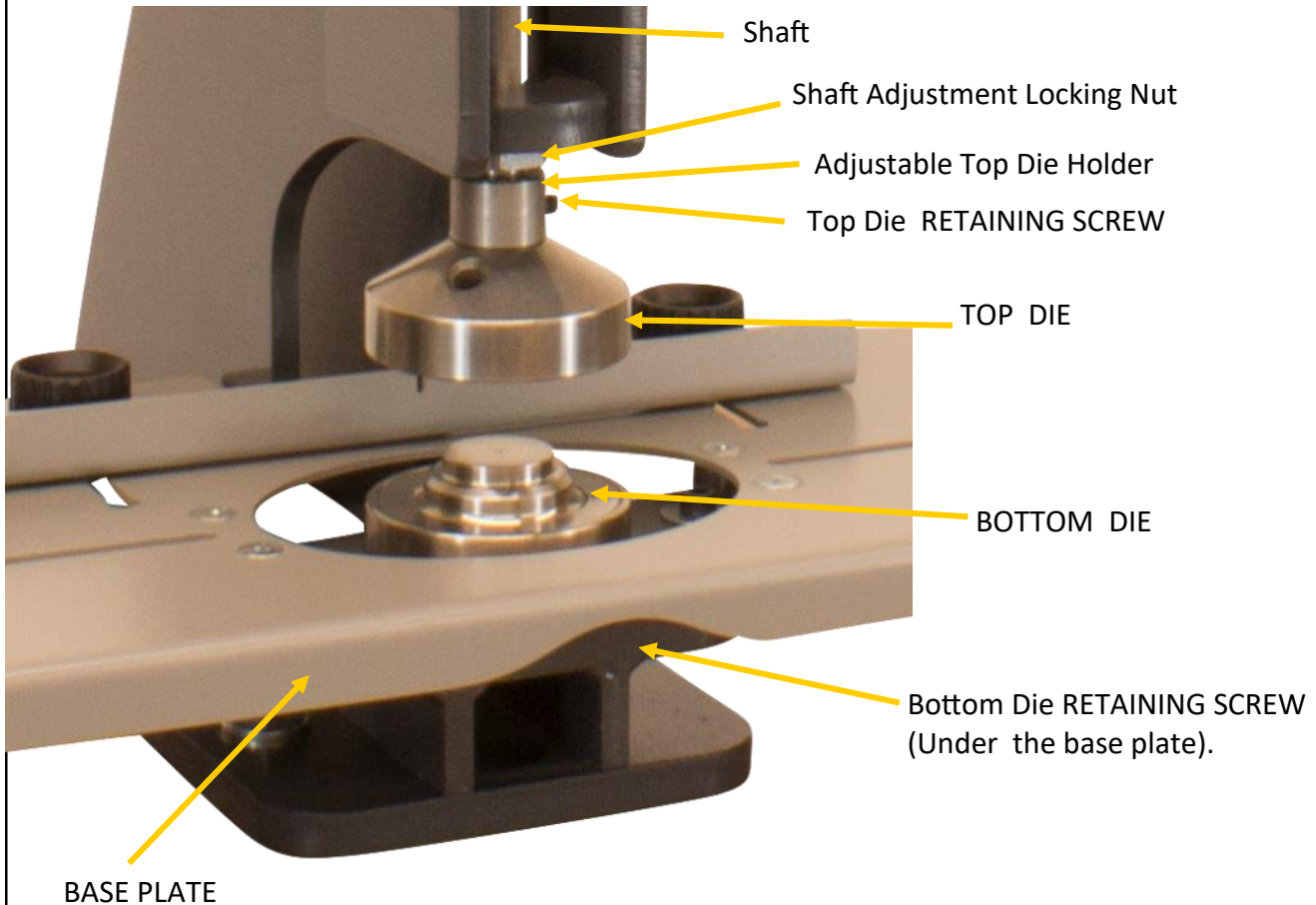

Separate V-Cutter & Setting Dies
(See Appendix A for setup and operation).

Fig 10



BASIC OPERATION OF THE PRESS

When viewed from the left hand side of the machine (see left and below) imagine the handle is a hand on a clock, in its normal REST position when waiting to be used the handle is at the "11 o'clock" position.

We operate the press by pulling the handle forward until it is at the "3 o'clock position" or horizontal position (below right)

The handle will not move further past the 3 o'clock position.

When the dies have been fitted correctly you will notice relatively free movement of the handle until it reaches just past the "2 o'clock" position. Pressure usually needs to be applied to the handle in order to complete the rotation to "3 o'clock" to complete it's cycle .

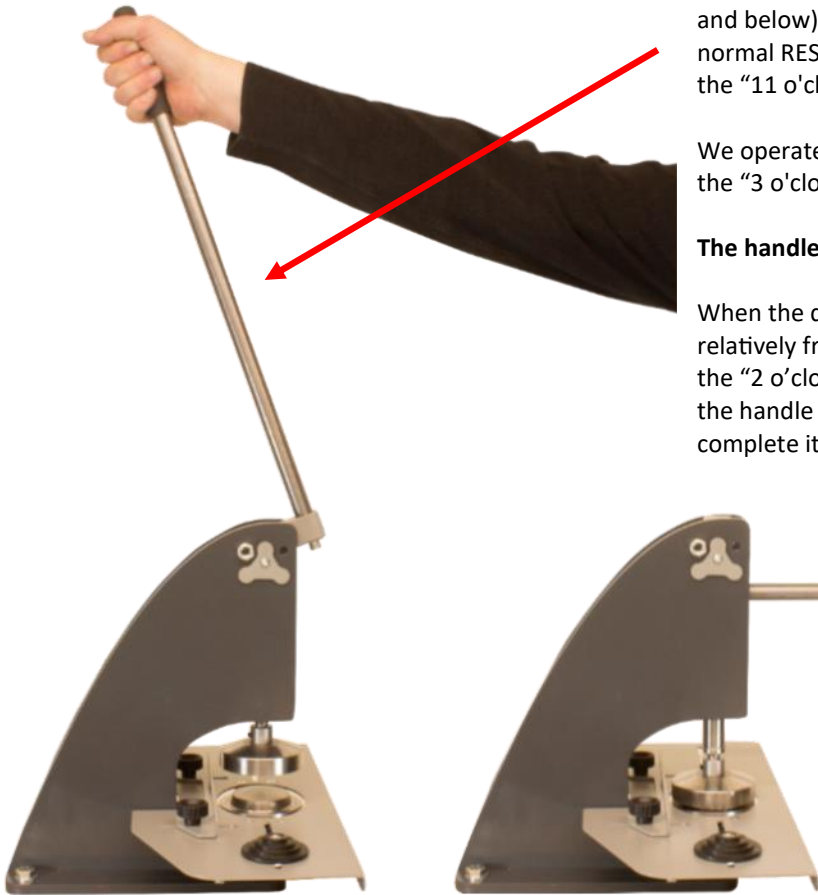

When installing any set of dies the cutting/setting pressure of the press must be adjusted so they will operate effectively.

It is crucial to understand how this process works to understand the next sections of these instructions about die set up and use.

Changes to the cutting/setting pressure of the press is achieved by adjusting the **upper die holder** which is screwed in to the bottom of the **shaft**.

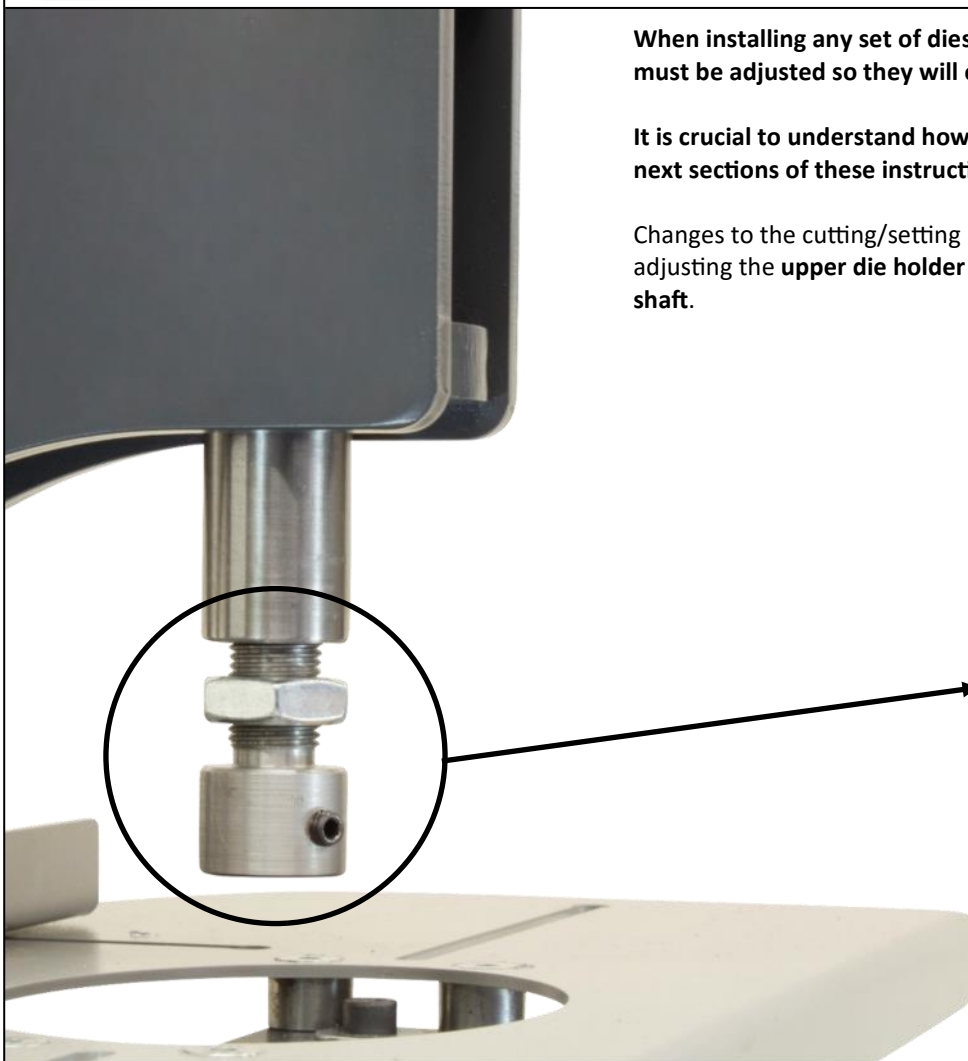

BASIC OPERATION OF THE PRESS



To make adjustments first loosen the **locking nut** (turn clockwise) with the spanner provided.

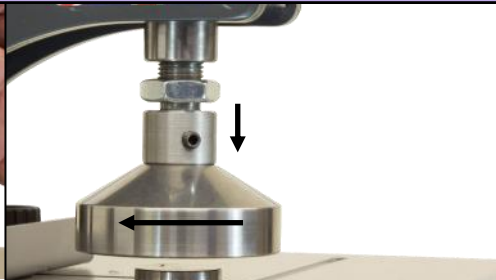

To increase pressure: screw the **upper die holder** downwards (also turning clockwise).

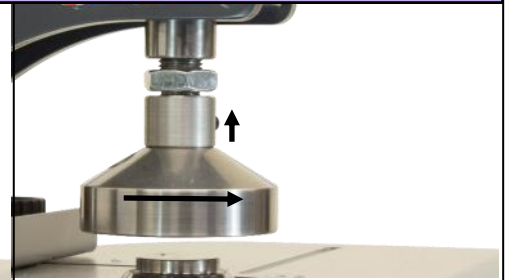

To reduce pressure screw the **upper die holder** upwards (turn anti-clockwise).



To lock in to position screw the **locking nut** tight up to the shaft (turning it anti-clockwise) and tighten with the spanner.



When installing new dies always start with the upper die holder screwed all the way up in to the shaft.

This machine is supplied with material location stops that assist the operator to accurately position the eyelets in the material.

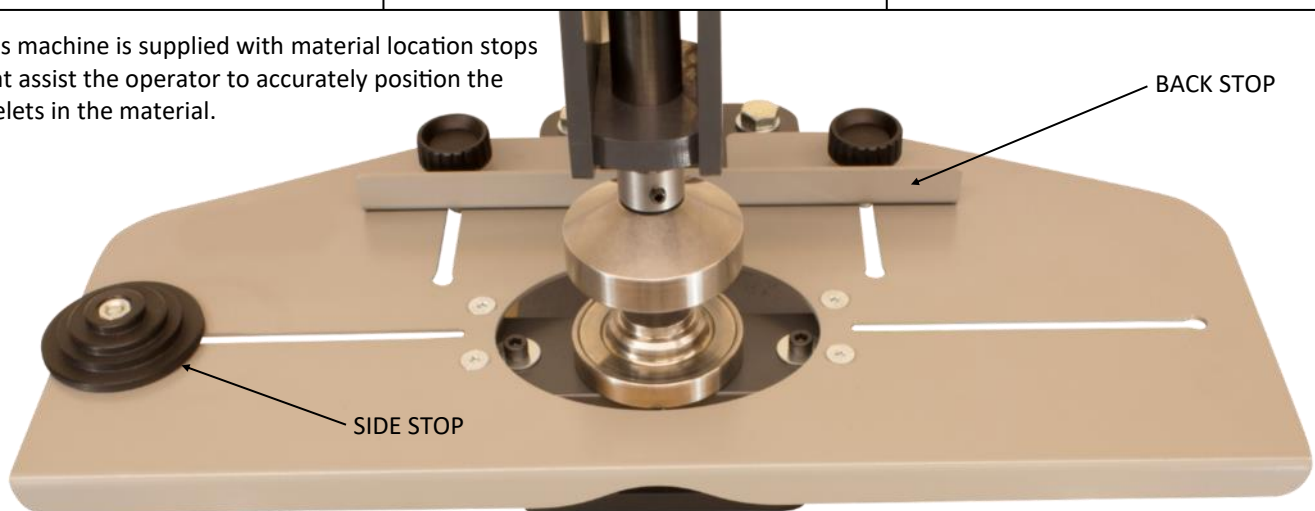

The **back stop** sets the distance from the top of the curtain, while the **side stop** controls the distance between each of the eyelets, the distance can be set between 10cm and 25cm centres.

This is achieved by un-screwing (turn anti-clockwise) and positioning the **side stop** to the desired distance then placing the previously set eyelet over nylon stop while the next hole is cut. The steps in the stop correspond to the diameters of the various sizes of hole in our range of curtain eyelets.

Depending on the preference of the operator the **side stop** can be used on either the left or the right hand side of the machine.

It is recommended that the operator practices with some waste material first to prevent errors in calculating the position of the eyelets.

As an alternative, you can use the back stop on its own and mark the position of the eyelets with pins. However please ensure that any pins are removed from the material before cutting as they will damage the dies.

COMBINATION DIES - INSTALLATION OF THE DIES



Step 1– As described on page 8 firstly lower the operating handle and with the supplied spanner loosen the shaft locking nut (turn clockwise) so the top die holder can turn freely. Then wind the top die holder anti clockwise upwards so it is fully wound up to the top.

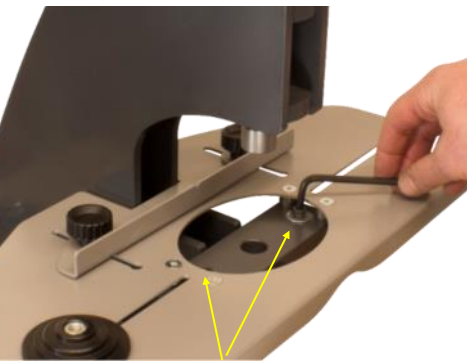

Step 2 - Loosen the two base plate screws on either side of the bottom die.



Step 3 - Insert the bottom die into the hole and tighten the retaining screw located under the base plate (see below)



Step 4 - Fit the top die in to the shaft & tighten the retaining screw (again any flat edge on the die should be towards the screw). Ensure the die is flat against the underside of the shaft. **DO NOT OVERTIGHTEN AS THIS WILL DAMAGE THE SETTING DIES.**



Step 5 - Gently lower the handle to the "3 o'clock" position.

Then turn the top die clockwise until it touches the bottom die whilst adjusting the base plate to move the bottom die so that both dies come together until there is no further movement.

When there is no further movement retighten the base plate screws while keeping the dies together.



Step 6 - Lift the operating handle slightly to release the top die and give it a further 180 degree turn, when you lower the handle again it should now sit at approximately 2 o'clock.



Finally retighten the locking nut (anti-clockwise) with the spanner and your dies should be ready to use.

It is important to do these steps each time the dies are changed or when any other part of the machine is adjusted!

COMBINATION DIES - OPERATION OF THE MACHINE



Step 1 - After aligning the dies as shown on the previous page, place a backing ring with its spikes facing upwards on to the bottom die (it should locate in the recess of the bottom die).



Step 2 - Place the material in the desired position where you want the eyelet over the bottom die and ring, the material should be face side up. Lower the top die on to the material and apply firm pressure until it cuts the material (there should be a positive click as it cuts) then lift the top die clear, this should reveal a hole in the material with the bottom die protruding through.



Step 3 - Take an eyelet and sit it on the bottom die that is now visible through the material.

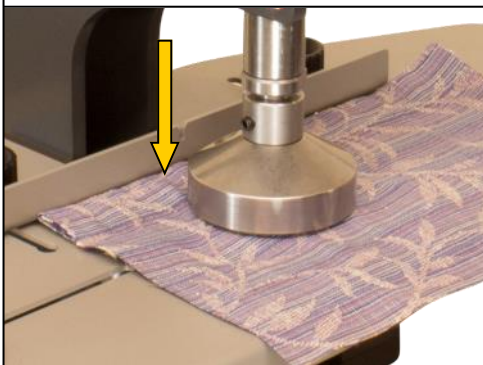

Step 4 - Lower the top die down again until it makes contact with the eyelet then apply firm pressure with the lever to cause the eyelet to push through the material and roll around the ring.

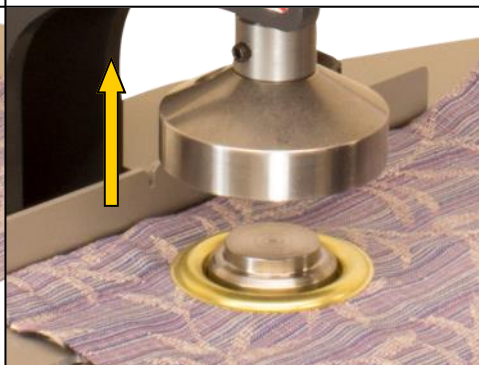

Step 5 - Lift the top die clear of the base die to release the fitted eyelet from the dies.

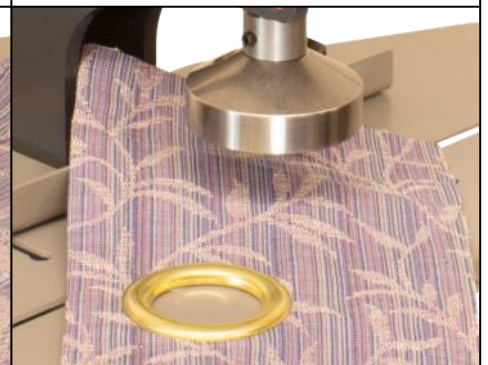

Step 6 - Inspect the eyelet to ensure it has correctly rolled and firmly gripped the material. (If necessary, you can re-apply pressure if the eyelet is still loose).

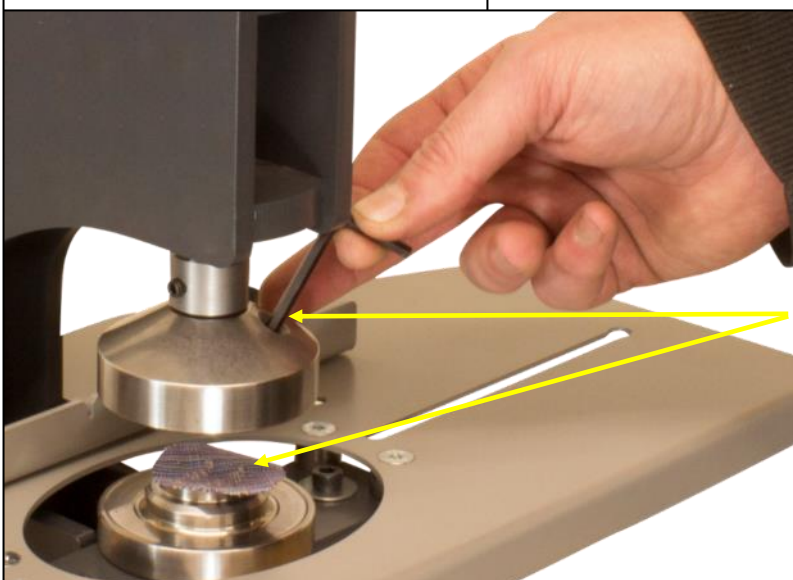

Simply repeat these steps for each eyelet in the curtain.

As you cut the holes, waste material will collect within the body of the top die, use the hexagon key supplied to push this waste material out. If waste material is allowed to build up in the top die it will affect the ability of the dies to set the eyelet.

MAINTENANCE

To ensure accuracy and long life the shaft and mechanism of the press should be oiled on a regular basis .

To avoid oil getting on to any work material it is advised that this is done on a “little and often basis”. i.e. a small amount of oil applied frequently rather than lots of oil in one go.

Always wipe the dies and work area to remove any excess oil before commencing work.

Oil areas marked in red using a general purpose mechanical oil.

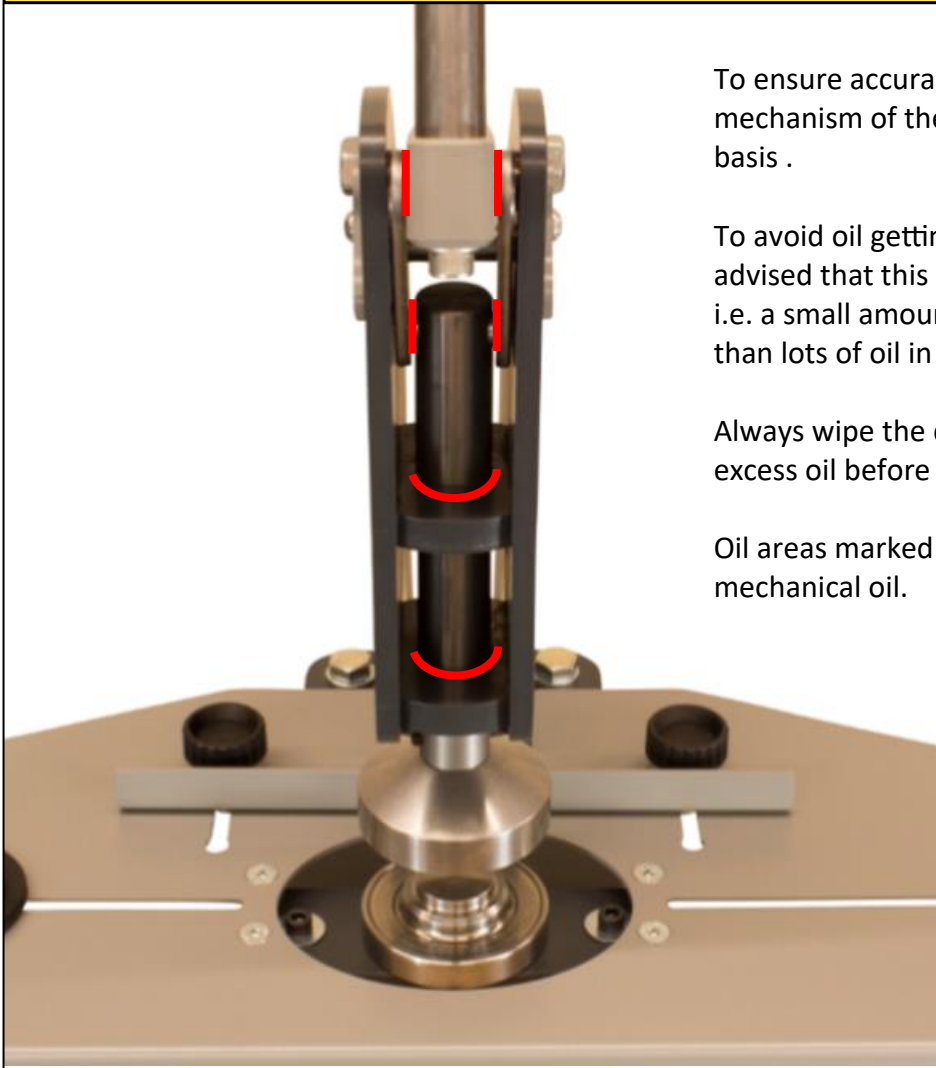

If you are unsure about any aspect of the set-up and operation or maintenance of this machine then please contact your supplier.

NOTES:

Appendix A Inserting eyelets with the Separate V-Cutter & Setting Dies

This section covers the slightly different method of fitting eyelets with the separate V-Cutter & Setting Dies as shown right.

Although suitable for the vast majority of materials, certain types of material do not lend themselves to being cut using the combination type dies as illustrated in the main part of the manual.

Some voiles, silks and certain heavy duty theatrical blackout materials can snag and pull threads when cut. In this situation pre-cutting the hole with a V-cutter will eliminate this problem in most cases.

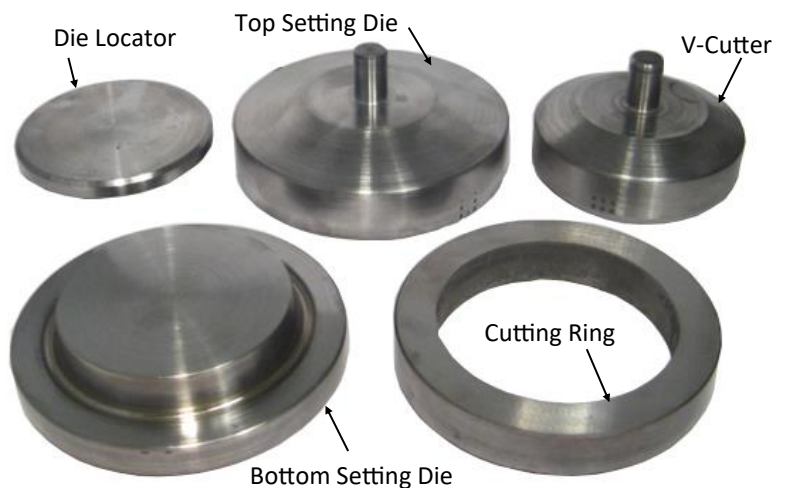

SETTING UP AND USING THE V-CUTTER



Step 1 - As with all die setups start by loosening the 2 M6 cap screws that hold the base plate in position as well as the shaft locking nut and screw the die holder up into the shaft.



Step 2 - Fit the die locator in to the base plate of the press and tighten the retaining screw. Then place the cutting ring over the die locator



Step 3 - Insert the v cutter in to the shaft & tighten the retaining screw



Step 4 - Using the operating handle gently lower the V-cutter until the handle is at "3 o'clock" then screw the die down until it makes contact with the cutting ring, move the baseplate at the same time to allow the dies to centralise with each other. When no further movement is possible retighten the 2 M6 Cap screws.



Step 5 - Use the operating handle to lift the top die slightly, then rotate it a further half a turn clockwise. Then tighten the locking nut by turning it anti-clockwise and nip it tight with the spanner, then return the operating handle to the rest position.



Step 6 - Place the material over the cutting ring in the desired position, lower the V-cutter down until it makes contact. Then apply firm pressure to cut the material. As it cuts it should make a firm click noise.

SET UP AND USE OF THE SETTING DIES

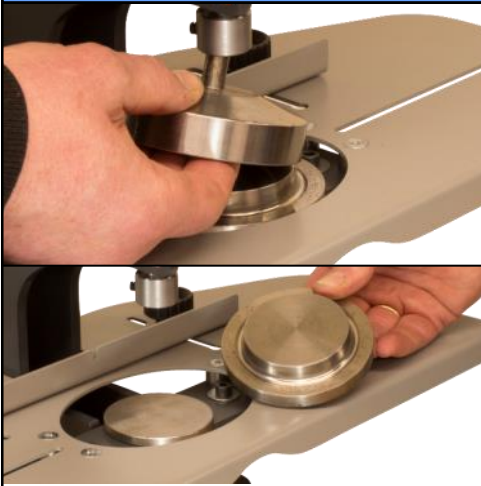

Step 1 - Remove the V-cutter and replace it with the **top setting die**. Lift the **cutting ring** off the **die locator** and replace that with the **bottom setting die**.



Step 2 - Place a backing ring with its spikes facing upwards on to the **bottom setting die**.

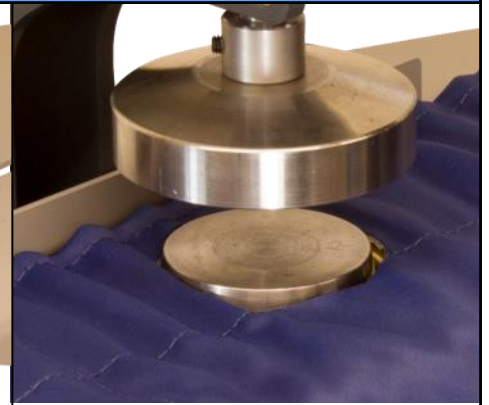

Step 3 - Place the material on the machine and locate one of the holes that you have just cut over the **bottom die** with the material face side up.

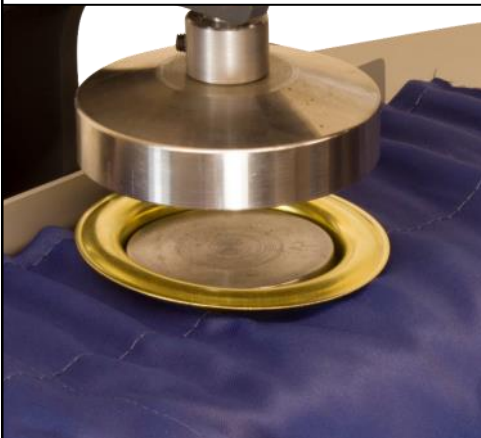

Step 4 - Take an eyelet and sit it on the **bottom setting die**, try not to trap any material between the eyelet and the **bottom setting die**.

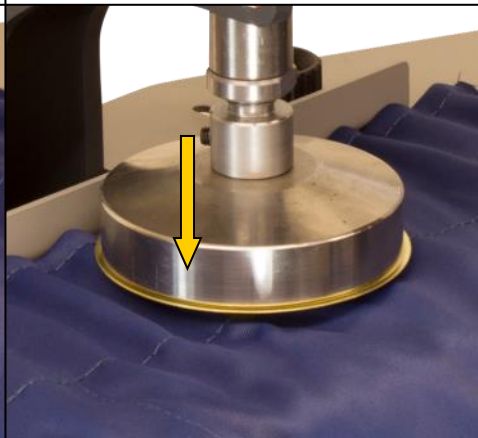

Step 5 - Lower the **top setting die** down until it makes contact with the eyelet then apply firm pressure with the lever to cause the eyelet to push through the material and roll around the ring.

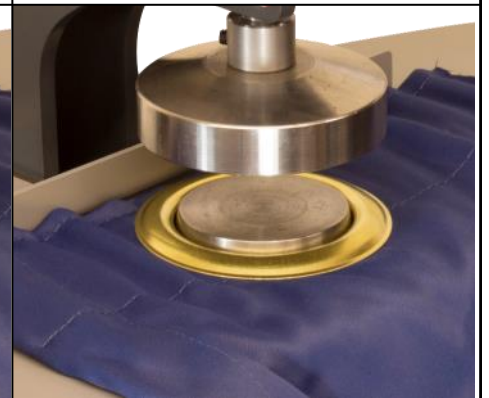

Step 6 - Lift the **top setting die** up to reveal the set eyelet .



Step 7 - Inspect the eyelet to ensure it has correctly gripped the material. If necessary put the eyelet back on the machine and apply more pressure to achieve a tighter grip.

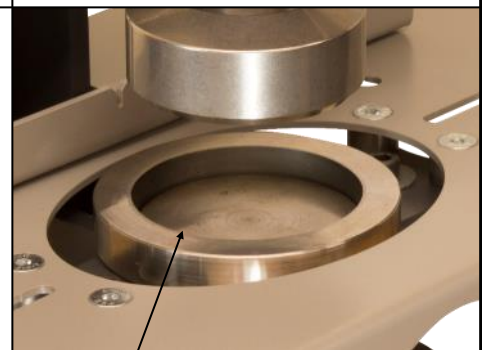

The **cutting ring** has two cutting edges, when one side becomes blunt simply turn the ring over and use the other side.

When both sides have become blunt they can be re-sharpened this is best done by returning them to your supplier.

Appendix B

Change From Front to Rear Operation

The Hallis press is unique in that it can be configured to be operated from either the front or from the rear.

Operation from the rear of the machine allows it to be located on or next to a work table where the curtain can remain on the table spread-out in front of the press while being eyeleted making it easier for the operator to handle the curtain.

Changing the configuration requires the internal mechanism to be rotated 180 degrees by following the procedure laid out in this section in this section.

Step 1 – Unscrew and remove the upper die holder and any dies still attached.

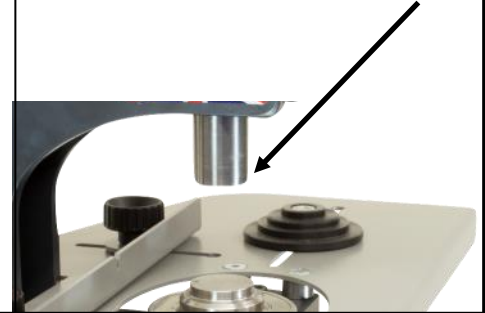

Step 2 - Remove the handle.

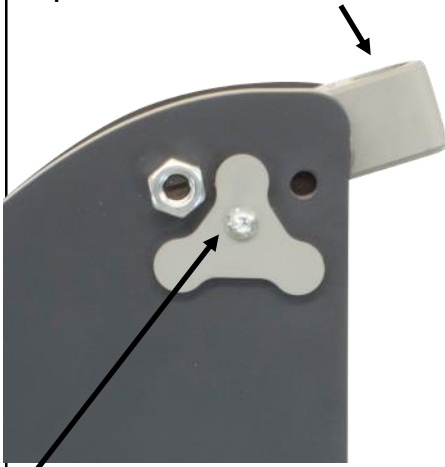

Then remove the triangular retention plates on either side of the press by unscrewing the domed cap screw in the centre.

Step 3 – Unscrew and remove the locking nuts that hold the spring plungers in position on both sides of the press.

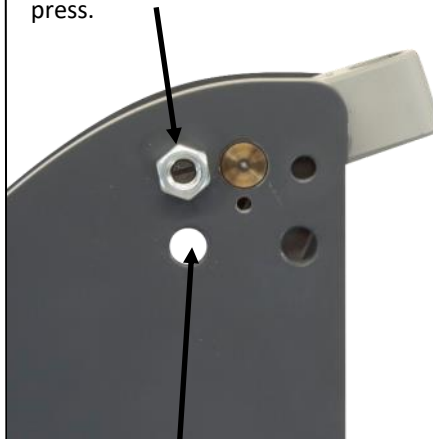

Also push out and remove the steel stop pin.

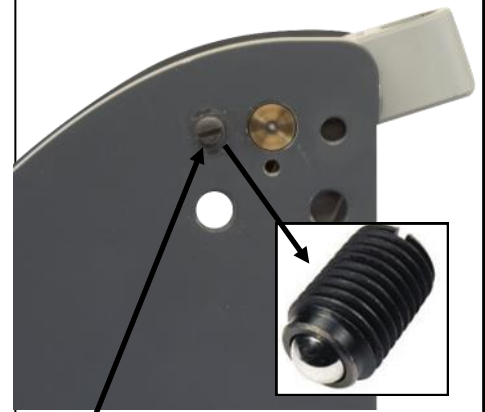

Step 4 - Take care as this next step will cause the shaft & drive unit to drop under their own weight. Use a screwdriver if needed and unscrew the two spring plungers on each side of the press and remove. Allow the mechanism to drop (see next image).



Step 5- Now remove the large main pin holding the drive unit in place.



Step 6– Start lifting the drive unit out of the frame of the press, then...



Step 7– As the linkage plates emerge hold them with your other hand so the mechanism does not fall apart.

SET UP AND USE OF THE SETTING DIES



Step 8 - Keep lifting until clear of the press frame and then rotate the whole mechanism 180 degrees.



Step 9 - Now gently lower the mechanism back down in to press frame.



Step 10 - While still holding the drive unit take the main pin and insert it back into the hole in the frame, guiding it into the drive unit and then through the other side of the frame until it is flush with both sides of the press.



Step 11 - Lift the mechanism up as above and insert the steel stop pin through the holes in the frame but now on the opposite side to where it was removed.



Step 12 - Carefully screw both spring plungers in to the holes on to the opposite side to where they were before. As you screw them in do it equally from either side of the press the spring pressure will grip the drive unit and hold it in place. Don't overtighten as this can cause damage.

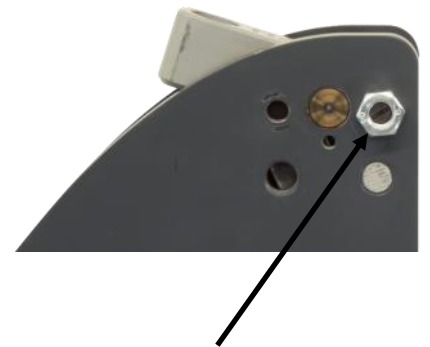

Step 13 - When you are satisfied with the position of the spring plungers screw the locking nuts onto them to prevent them from moving.



Step 14 - Refit the retention plates on either side, these plates hold the pins in place preventing them coming apart.



Step 15 - Insert the handle in the drive unit and lower it down to horizontal position.



Step 16 - with the handle in this position it's easier to refit the handle screw from the other side.

Once the handle is secured the machine is ready to be used from the opposite side. Simply follow these instructions in reverse if you want to change from back to front operation.



Hallis Hudson Group Ltd
Unit 34 Red Scar Business Park, Preston, Lancashire, PR2 5NN
Online **Halliswebshop.com**
Email **sales@hallishudson.com**
Fax 01772 515 515
Phone **01772 202 202**