

SG 2304 & 2305 ASSEMBLY INSTRUCTIONS

(1)

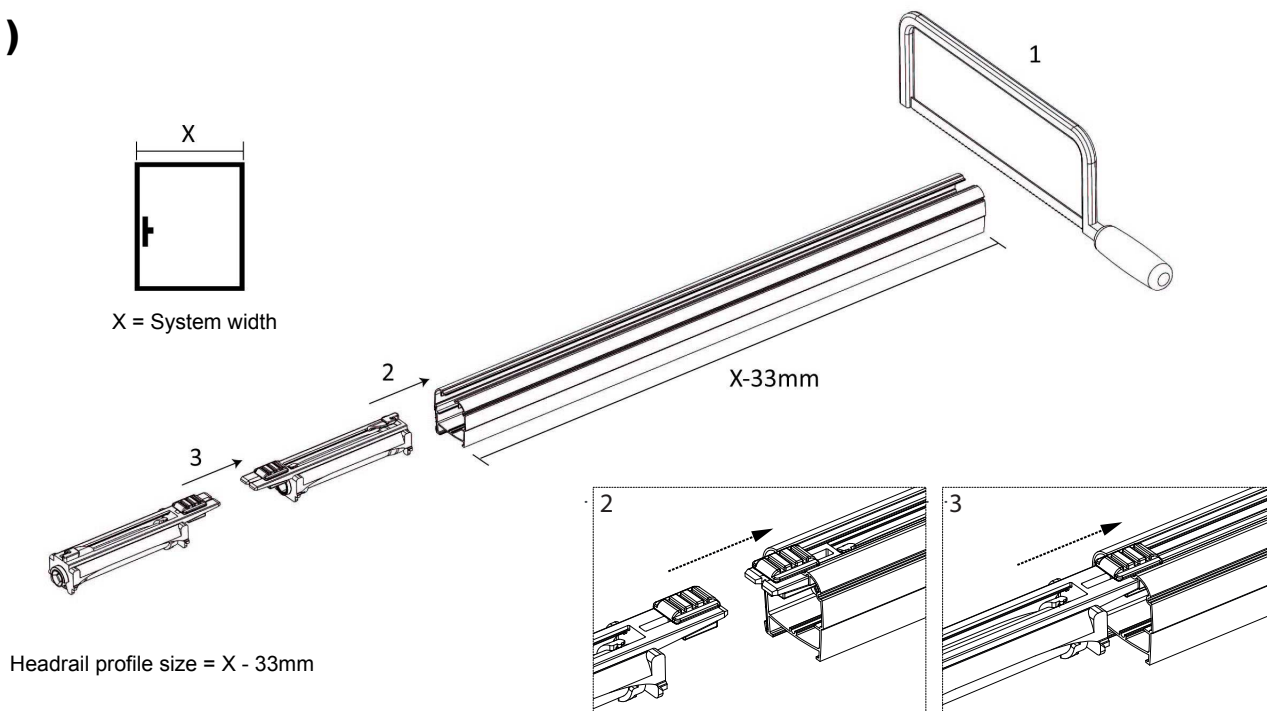

(2)

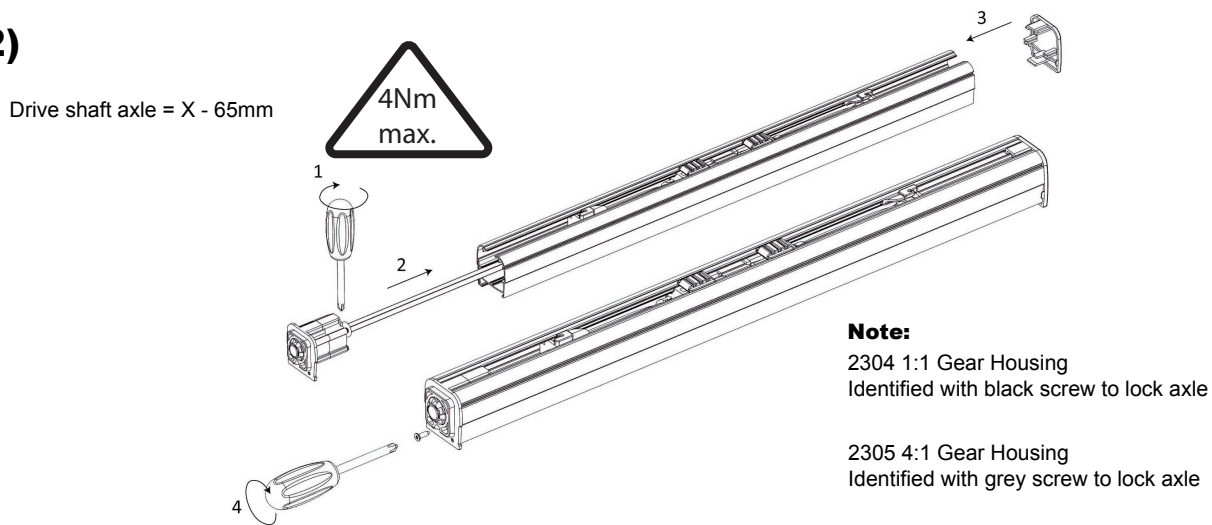

(3)

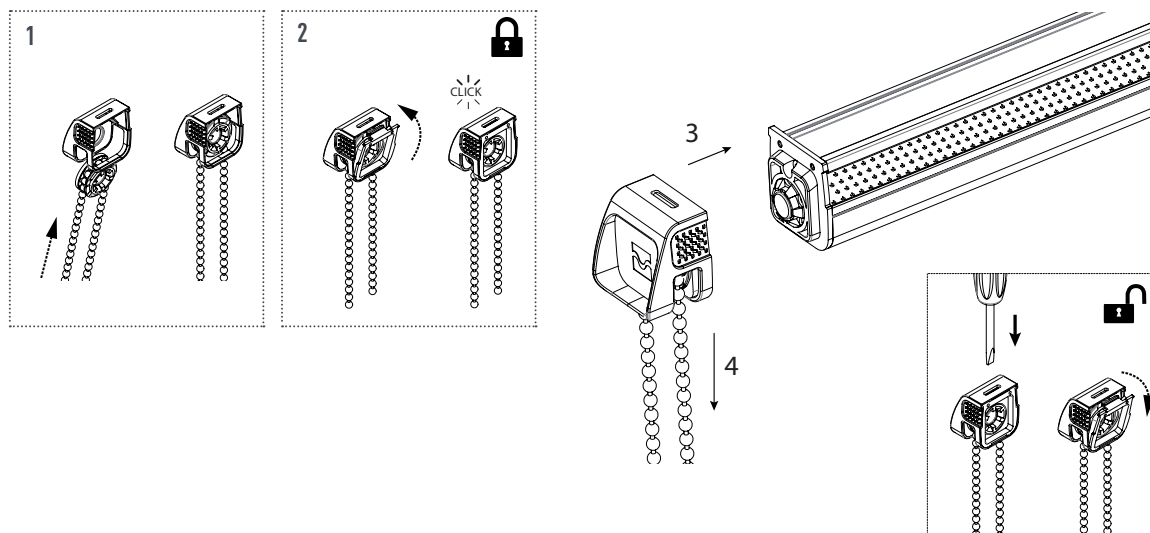

(4)

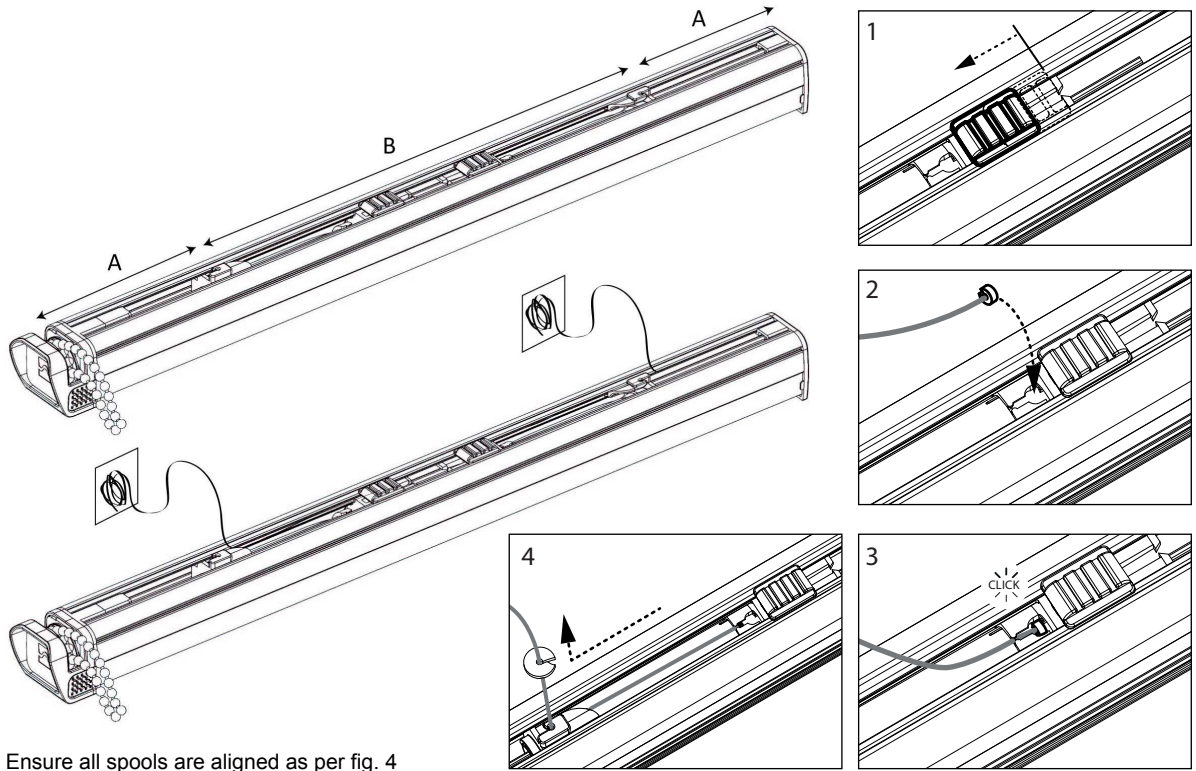

Ensure all spools are aligned as per fig. 4
